



# Cambridge IGCSE™

CANDIDATE  
NAME

CENTRE  
NUMBER

--	--	--	--	--

CANDIDATE  
NUMBER

--	--	--	--



**MATHEMATICS**

**0580/41**

Paper 4 (Extended)

**October/November 2023**

**2 hours 30 minutes**

You must answer on the question paper.

You will need: Geometrical instruments

## INSTRUCTIONS

- Answer **all** questions.
- Use a black or dark blue pen. You may use an HB pencil for any diagrams or graphs.
- Write your name, centre number and candidate number in the boxes at the top of the page.
- Write your answer to each question in the space provided.
- Do **not** use an erasable pen or correction fluid.
- Do **not** write on any bar codes.
- You should use a calculator where appropriate.
- You may use tracing paper.
- You must show all necessary working clearly.
- Give non-exact numerical answers correct to 3 significant figures, or 1 decimal place for angles in degrees, unless a different level of accuracy is specified in the question.
- For  $\pi$ , use either your calculator value or 3.142.

## INFORMATION

- The total mark for this paper is 130.
- The number of marks for each question or part question is shown in brackets [ ].

This document has **20** pages. Any blank pages are indicated.

1

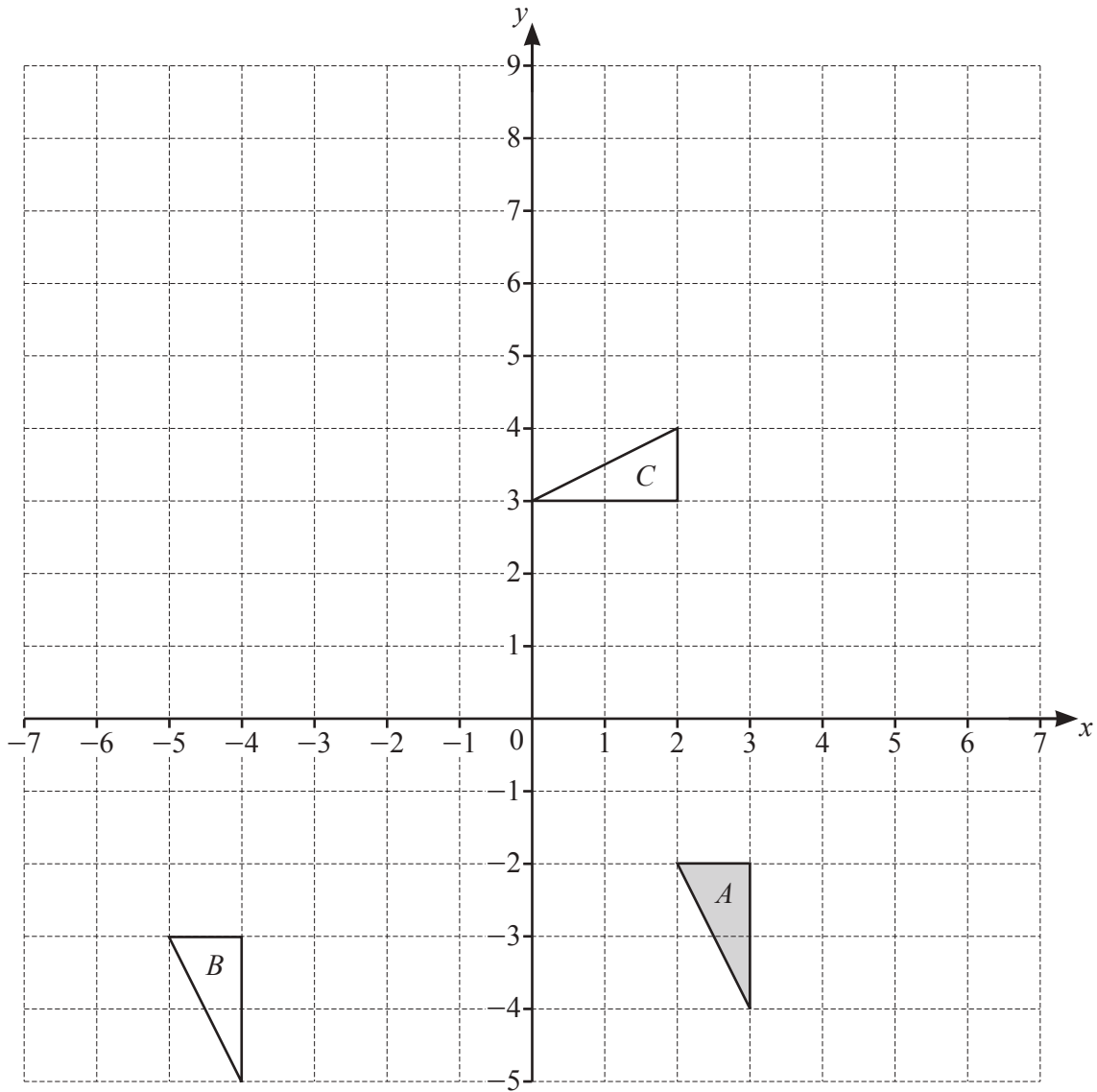

(a) Describe fully the **single** transformation that maps

(i) shape *A* onto shape *B*

.....  
 ..... [2]

(ii) shape *A* onto shape *C*.

.....  
 ..... [3]

(b) On the grid, draw the image of

(i) shape *A* after a reflection in the line  $y = 2$  [2]

(ii) shape *A* after an enlargement, scale factor  $-2$ , centre  $(0, 0)$ . [2]

2 (a)  $s = \frac{1}{2}at^2$

Find the value of  $s$  when  $a = 9.8$  and  $t = 20$ .

$s = \dots\dots\dots$  [2]

(b) Solve.

$$5(4y - 3) = 15$$

$y = \dots\dots\dots$  [3]

(c) Expand and simplify.

$$3(5x - 8) - 2(3x - 7)$$

$\dots\dots\dots$  [2]

(d) Rearrange  $A = 2b^2 - 3c^3$  to make  $c$  the subject.

$c = \dots\dots\dots$  [3]

(e) Factorise completely.

$$6pq - 4q - 3p + 2$$

$\dots\dots\dots$  [2]

- 3 (a) The table shows information about some of the planets in the solar system.

Planet	Diameter (km)	Average distance from the Sun (km)
Earth	12 800	$1.496 \times 10^8$
Mars	6 800	$2.279 \times 10^8$
Jupiter	143 000	$7.786 \times 10^8$
Saturn	120 500	$1.434 \times 10^9$
Neptune	49 500	$4.495 \times 10^9$

- (i) The average distance of Mars from the Sun is  $2.279 \times 10^8$  km.

Write this distance as an ordinary number.

..... km [1]

- (ii) The planet Uranus has a diameter that is 35.8% of the diameter of Jupiter.

Calculate the diameter of Uranus.

..... km [2]

- (iii) The ratio diameter of Neptune : diameter of Saturn can be written in the form  $1 : n$ .

Find the value of  $n$ .

$n =$  ..... [1]

- (iv) Find the average distance of Neptune from the Sun as a percentage of the average distance of the Earth from the Sun.

..... % [2]

- (v) Distances within the solar system are also measured in astronomical units (AU).  
The average distance of Jupiter from the Sun is 5.20 AU.

Calculate the average distance of Mars from the Sun in astronomical units.

..... AU [2]

- (vi) The diameter of Mars is 39.2% greater than the diameter of Mercury.

Calculate the diameter of Mercury.

..... km [2]

- (b) One light year is the distance that light travels in a year of 365.25 days.  
The speed of light is  $2.9979 \times 10^5$  kilometres per second.

- (i) Show that one light year is  $9.461 \times 10^{12}$  km, correct to 4 significant figures.

[2]

- (ii) The distance from the Andromeda Galaxy to Earth is  $2.40 \times 10^{19}$  km.

Calculate the time taken for light to travel from this galaxy to Earth.  
Give your answer in millions of years.

..... million years [2]

- 4 (a) Lucia has two fair spinners.  
 Spinner *A* is five-sided and is numbered 1, 2, 3, 4, 5.  
 Spinner *B* is nine-sided and is numbered 3, 3, 3, 4, 4, 4, 4, 5, 5.

Lucia spins the two spinners and records whether they land on a prime number.

- (i) Complete the tree diagram.

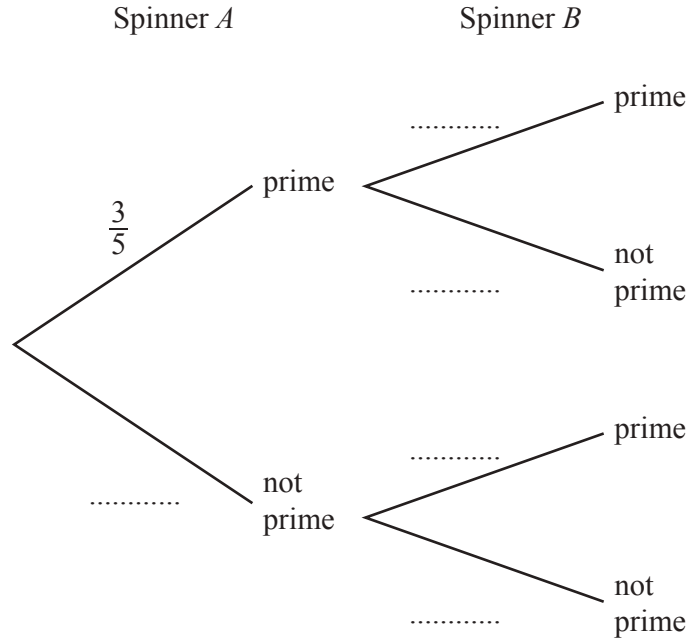

[2]

- (ii) Find the probability that

- (a) the two numbers are both prime

..... [2]

- (b) the two numbers are **not** both prime.

..... [1]

- (b) Lucia spins Spinner  $A$  120 times.

Find the expected number of times the spinner lands on a prime number.

..... [1]

- (c) Lucia spins Spinner  $B$  twice.

Find the probability that the two numbers it lands on add up to 9 or more.

..... [3]

- (d) Lucia keeps spinning Spinner  $B$  until it lands on a 4.

Find an expression, in terms of  $n$ , for the probability that this happens on the  $n$ th spin.

..... [2]

5 (a)

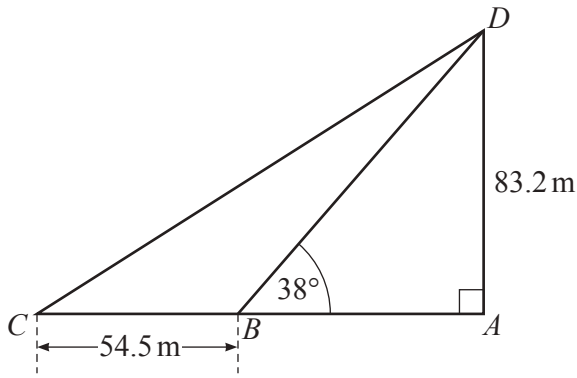

NOT TO SCALE

$ACD$  is a right-angled triangle.  
 $B$  is on  $AC$  and  $BC = 54.5$  m.  
 $AD = 83.2$  m and angle  $ABD = 38^\circ$ .

Calculate angle  $ACD$ .

Angle  $ACD = \dots\dots\dots$  [5]

(b)

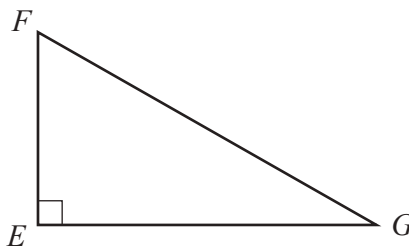

$EFG$  is a right-angled triangle.  
 A circle can be drawn that passes through the three vertices of the triangle.

On the diagram, mark the position of the centre of the circle with a cross.  
 Explain how you decide.

.....  
 .....

[2]

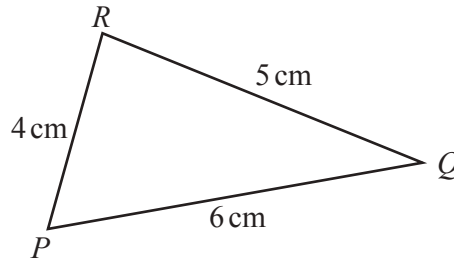
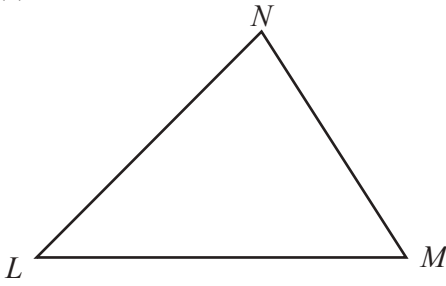

(c)

NOT TO  
SCALE

In triangle  $LMN$ , the ratio angle  $L$  : angle  $M$  : angle  $N = 4 : 5 : 6$ .

In triangle  $PQR$ ,  $PQ = 6 \text{ cm}$ ,  $PR = 4 \text{ cm}$  and  $QR = 5 \text{ cm}$ .

Calculate the difference between the largest angle in triangle  $PQR$  and the largest angle in triangle  $LMN$ .

..... [7]

6 (a)

Sequence	1st term	2nd term	3rd term	4th term	5th term		$n$ th term
A	-7	-3	1	5			
B	7	13	23	37			
C	$\frac{2}{27}$	$\frac{3}{81}$	$\frac{4}{243}$	$\frac{5}{729}$			

Complete the table for the three sequences.

[10]

- (b) In a sequence, the sum of the first 49 terms is 7644.  
The sum of the first 50 terms is 7975.

Find the 50th term of this sequence.

..... [1]

7 The frequency table shows the time of each of 42 athletes in a race.

Time ( $t$ seconds)	Number of athletes
$216 < t \leq 219$	9
$219 < t \leq 224$	14
$224 < t \leq 234$	14
$234 < t \leq 244$	2
$244 < t \leq 264$	3

(a) Calculate an estimate of the mean time.

..... seconds [4]

(b) Complete the histogram to show the information in the frequency table. Two of the blocks have been drawn for you.

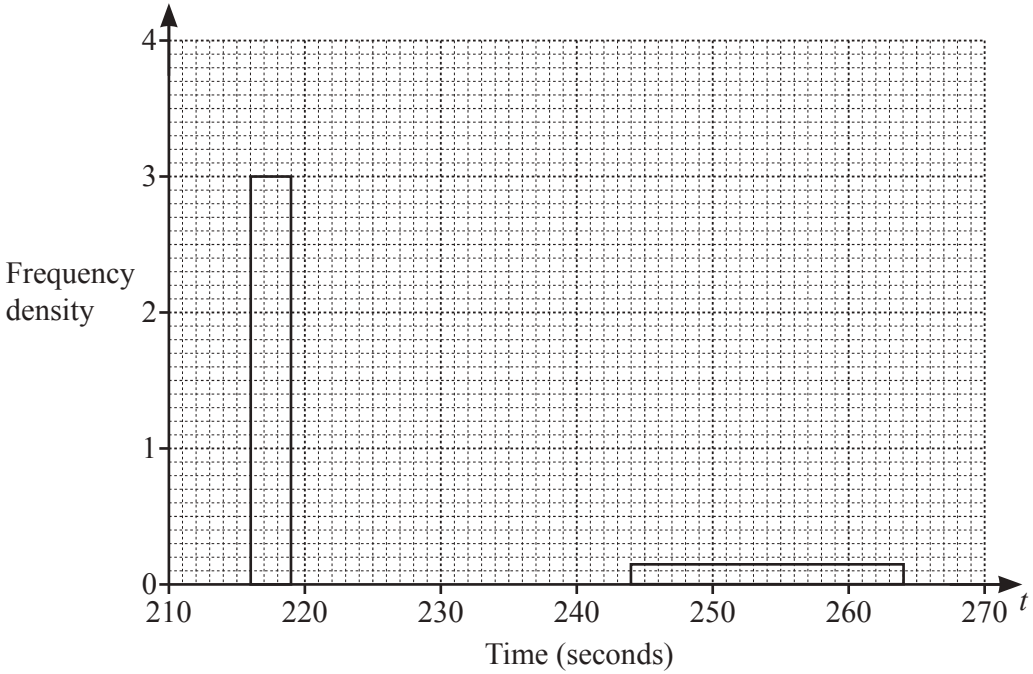

[3]

8 (a)

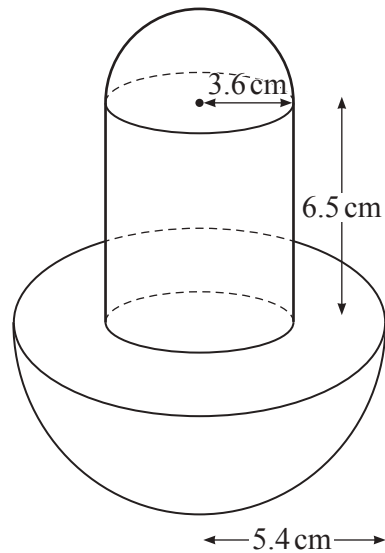
NOT TO  
SCALE

The diagram shows a solid formed by joining two hemispheres and a cylinder.  
 The radius of the large hemisphere is 5.4 cm.  
 The radius of the small hemisphere and the radius of the cylinder are both 3.6 cm.  
 The height of the cylinder is 6.5 cm.

- (i) Show that the volume of the solid is  $692 \text{ cm}^3$ , correct to the nearest cubic centimetre.

[The volume,  $V$ , of a sphere with radius  $r$  is  $V = \frac{4}{3}\pi r^3$ .]

[4]

- (ii) A mathematically similar solid is made of silver.  
 In this solid, the cylinder has radius 0.6 cm.  
 $1 \text{ cm}^3$  of silver has a mass of 10.49 grams.

Calculate the total mass of this silver solid.

..... g [4]

(b)

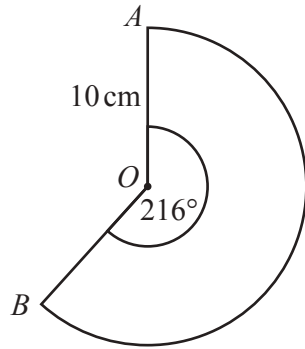

NOT TO SCALE

*AOB* is a sector of a circle, centre *O*.  
*AO* = 10 cm and the sector angle is  $216^\circ$ .

- (i) Calculate the length of the arc of this sector.  
 Give your answer as a multiple of  $\pi$ .

.....cm [2]

- (ii) A cone is made from this sector by joining *OA* to *OB*.

Calculate the volume of the cone.

[The volume,  $V$ , of a cone with radius  $r$  and height  $h$  is  $V = \frac{1}{3}\pi r^2 h$ .]

.....  $\text{cm}^3$  [4]

9  $f(x) = (3x+1)(x+5)(x-4)$      $g(x) = 2x-3$      $h(x) = 4^{2x-1}$

(a) Find

(i)  $f(0)$

..... [1]

(ii)  $g^{-1}(x)$

$g^{-1}(x) =$  ..... [2]

(iii)  $gh(2)$ .

..... [2]

(b)  $g(2x) = 7$

Find the value of  $x$ .

$x =$  ..... [2]

(c) Simplify  $g(x^2) + gg(x) + 1$ .

..... [3]

(d) Find  $h^{-1}(16)$ .

..... [2]

(e)  $f(x) = (3x + 1)(x + 5)(x - 4)$

This can be written in the form  $f(x) = ax^3 + bx^2 + cx + d$ .

Find the value of each of  $a$ ,  $b$ ,  $c$  and  $d$ .

$a = \dots\dots\dots b = \dots\dots\dots c = \dots\dots\dots d = \dots\dots\dots$  [3]

10 (a)  $ABC$  is a triangle.

$B$  is the point  $(1, -10)$ ,  $A$  is the point  $(4, 14)$  and  $\vec{CA} = \begin{pmatrix} -11 \\ 8 \end{pmatrix}$ .

(i) Find the coordinates of  $C$ .

(....., .....) [2]

(ii) Find  $\vec{BA}$ .

$$\vec{BA} = \begin{pmatrix} \phantom{0} \\ \phantom{0} \end{pmatrix} \quad [1]$$

(iii) Find  $|\vec{CA}|$ .

..... [2]



(b)

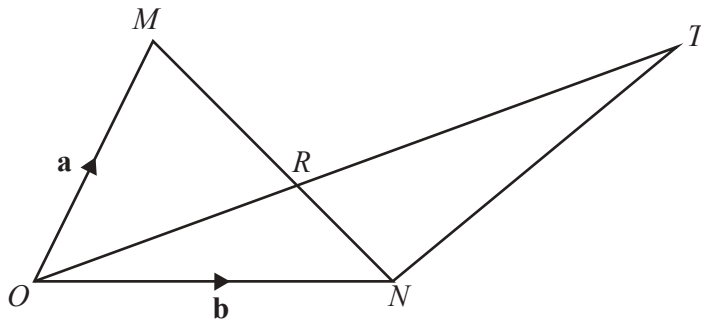

NOT TO SCALE

$OMN$  is a triangle.

$\vec{OM} = \mathbf{a}$  and  $\vec{ON} = \mathbf{b}$ .

$R$  is a point on  $MN$  such that  $MR : RN = 3 : 2$ .

$ORT$  is a straight line.

(i) Show that  $\vec{OR} = \frac{2}{5}\mathbf{a} + \frac{3}{5}\mathbf{b}$ .

[3]

(ii) (a)  $\vec{NT} = 4\mathbf{a} + k\mathbf{b}$  and  $\vec{OT} = c\vec{OR}$ .

Find the value of  $k$  and the value of  $c$ .

$k = \dots\dots\dots c = \dots\dots\dots$  [4]

(b) Find  $\vec{MT}$ .

$\vec{MT} = \dots\dots\dots$  [1]

11 (a) Differentiate  $x^3 - 4x^2 - 3x$ .

..... [2]

(b) A curve has equation  $y = x^3 - 4x^2 - 3x$ .

Work out the coordinates of the two stationary points.  
Show all your working.

(....., .....) )

(....., .....) [5]

- (c) Determine whether each stationary point is a maximum or a minimum.  
Show all your working.

[3]